

	W 5.5W LED lm 350 Lumen t 15.000h T_k 3.000 Kelvin 7.500 x 0s 4-Stufen Dimmer 4-steps dimmer	7591	
		230V/50Hz	
	LED	1 x LED-Board max. 5.5W	

(on) — (off) — (on) — (off) — (on) — (off) — (on)

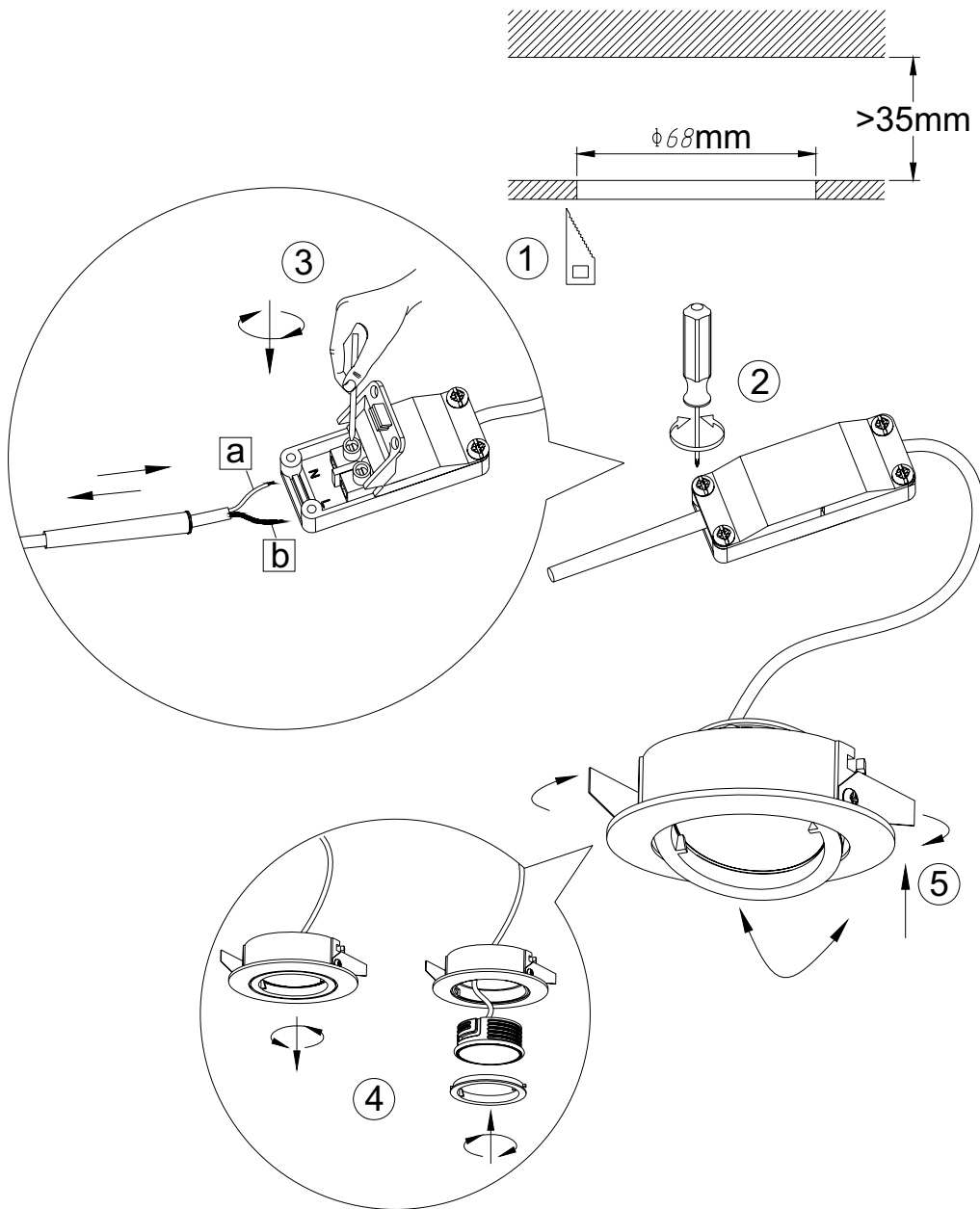

4-Stufen Dimmer/ 4-steps dimmer



Bitte geben Sie bei technischen Fragen die Chargennummer (xxxxx-xx-xx-xxxxx-xxx) an. Diese finden Sie auf dem Typenschild.
 Please let us know the batch number (xxxxx-xx-xx-xxxxx-xxx) for any technical questions. This can be found on the rating label.
 Lors de demande d'assistance technique, veuillez indiquer le numéro du lot (xxxxx-xx-xx-xxxxx-xxx). Celui-ci se trouve sur la plaque d'identification.

10/2015