

W 6W  
 LED  
 Im 500 Lumen  
 t 25.000h  
 T<sub>k</sub> 3.000 Kelvin  
 12.500 x  
 0s

# 6788-96

230V / 50Hz 3 X LED-Board max. 13.5V / 6W

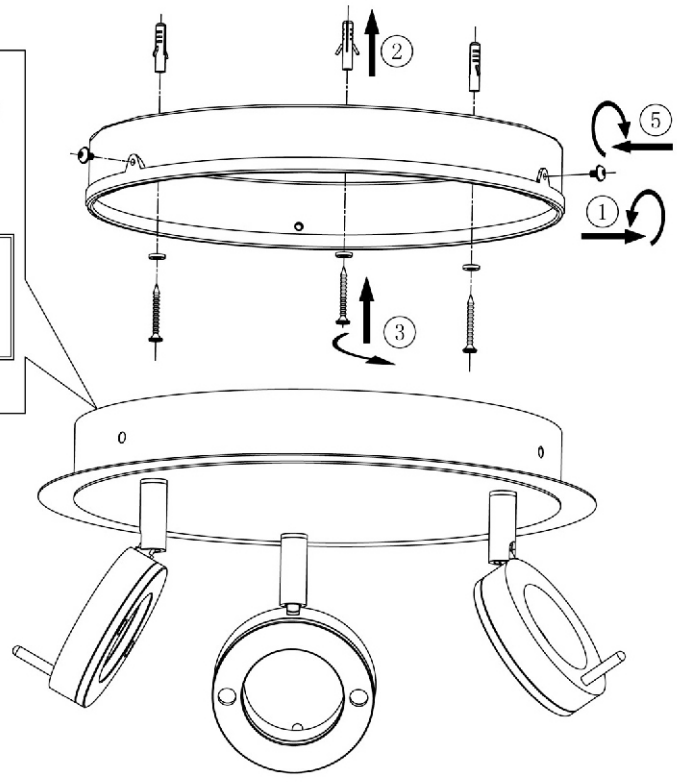
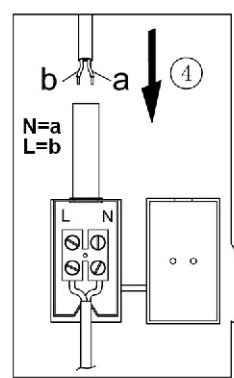
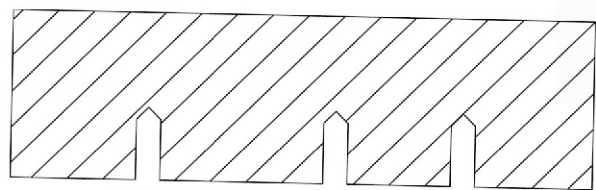

Bitte geben Sie bei technischen Fragen die Chargennummer (xxxxx-xx-xx-xxxxx-xxx) an. Diese finden Sie auf dem Typenschild.  
 Please let us know the batch number (xxxxx-xx-xx-xxxxx-xxx) for any technical questions. This can be found on the rating plate.  
 Lors de demande d'assistance technique, veuillez indiquer le numéro du lot (xxxxx-xx-xx-xxxxx-xxx ). Celui-ci se trouve sur la plaque d'identification.

05/2015