

W 9.60W
 LED
 lm 984 Lumen
 t 20.000h
 T_k 3.000 Kelvin
 8.000 x
 0 s

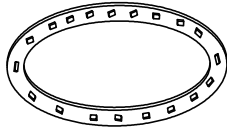

14262-95



230V / 50Hz 1xLED-Board max.20V/9.60W

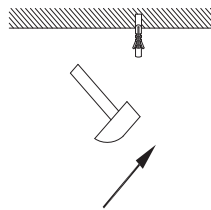
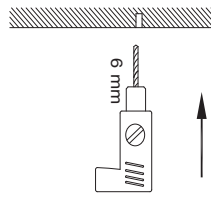
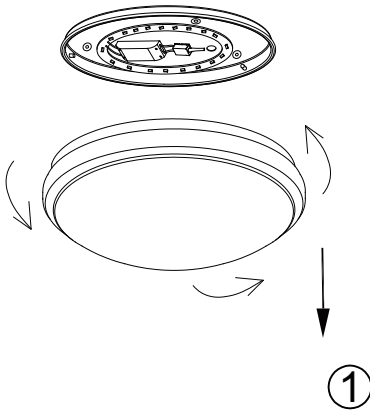
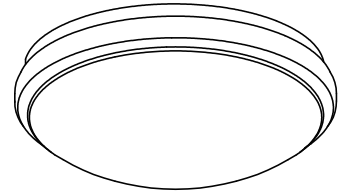

②

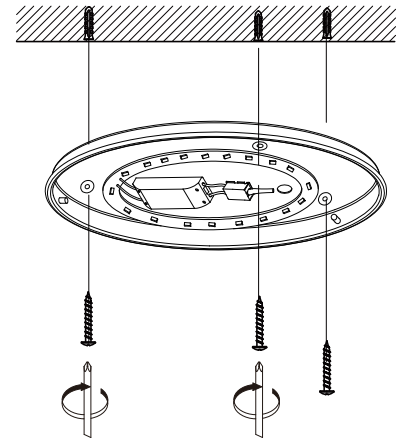

③

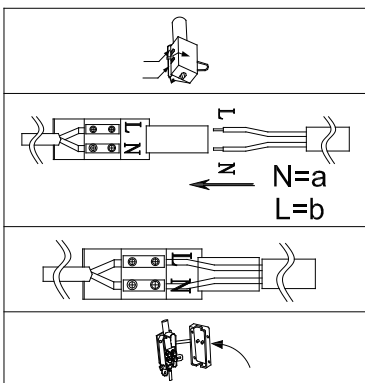

④

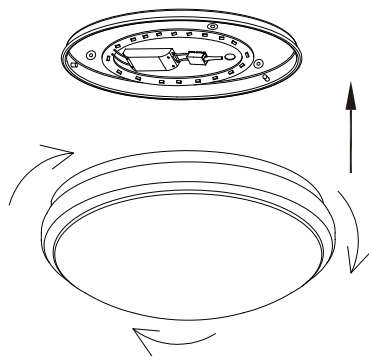

⑤

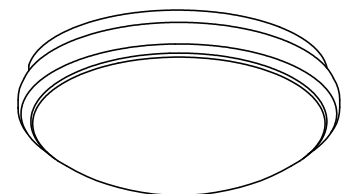

⑥

Bitte geben Sie bei technischen Fragen die Chargennummer (xxxx-xx-xx-xxxx-xxx) an. Diese finden Sie auf dem Typenschild.

Please let us know the batch number (xxxx-xx-xx-xxxx-xxx) for any technical questions. This can be found on the rating label.

Lors de demande d'assistance technique, veuillez indiquer le numéro du lot (xxxx-xx-xx-xxxx-xxx). Celui-ci se trouve sur la plaque d'identification.

In caso di domande di tipo tecnico, si prega di specificare il numero di lotto (xxxx-xx-xx-xxxx-xxx) indicato sulla targhetta identificativa.

07/2014