

	W 19W LED lm 1.920 Lumen t 25.000h T_k 3.000 Kelvin 12.500 x 0s 	6629	
		230V/50Hz	
	LED	1 x LED-Board/ max. 19W	

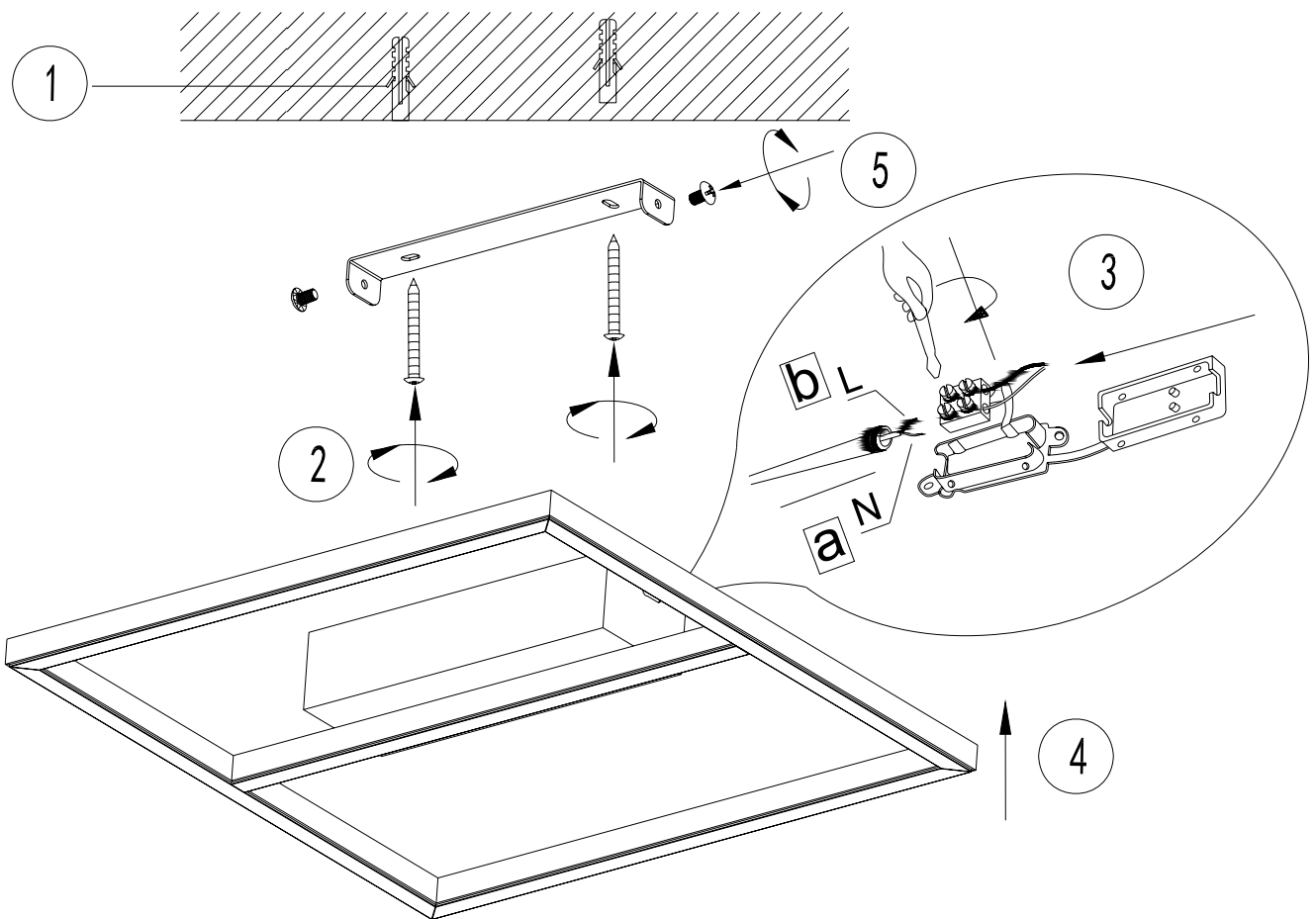

Bitte geben Sie bei technischen Fragen die Chargennummer (xxxxx-xx-xx-xxxxx-xxx) an. Diese finden Sie auf dem Typenschild.
 Please let us know the batch number (xxxxx-xx-xx-xxxxx-xxx) for any technical questions. This can be found on the rating label.
 Lors de demande d'assistance technique, veuillez indiquer le numéro du lot (xxxxx-xx-xx-xxxxx-xxx). Celui-ci se trouve sur la plaque d'identification.

03/2015