

W 3.83W
 LED LED
 lm 345 Lumen
 t 20.000 h
 T_k 3000 Kelvin
 15.000 x
 0 s
 GIRA 30700
 Berker 2874
 Jung 225 TDE

6381-55

230V/50HZ

LED

12XLED max.3.83W

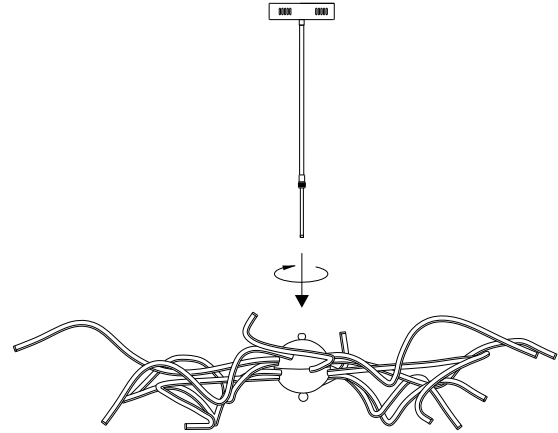
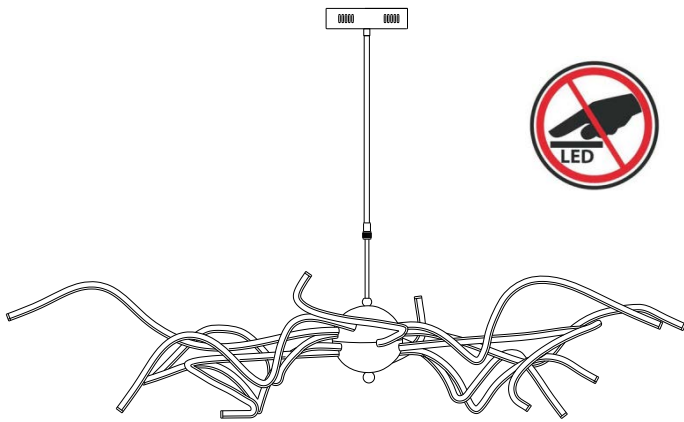

01

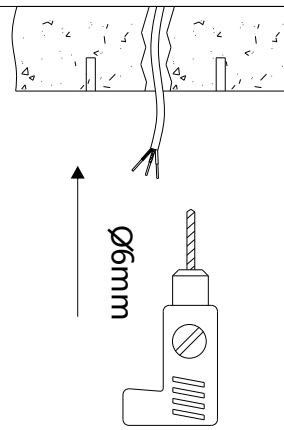

02

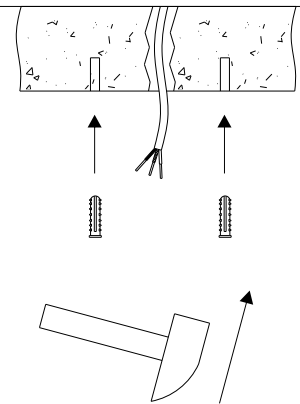

03

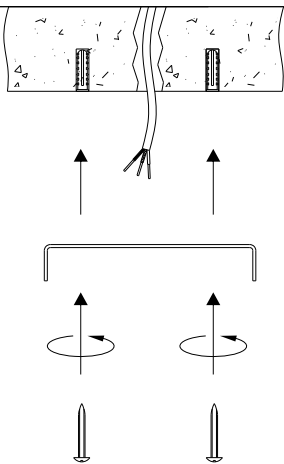

04

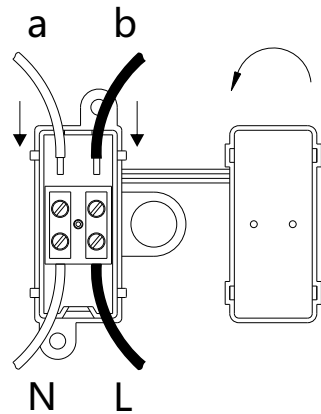

05

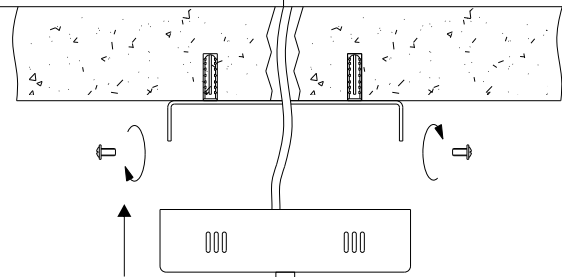

06

Bitte geben Sie bei technischen Fragen die Chargennummer(XXXXX-XX-XX-XXXXX-XXX)an.Diese finden Sie auf dem Typenschild.

Please let us know the batch number(XXXXX-XX-XX-XXXXX-XXX)for any technical questions.This can be found on the rating plate.

Lors de demande d'assistance technique,veuillez indiquer le numero du lot(XXXXX-XX-XX-XXXXX-XXX-).Celui-ci se trouve sur la plaque d'identification.

02/2016