

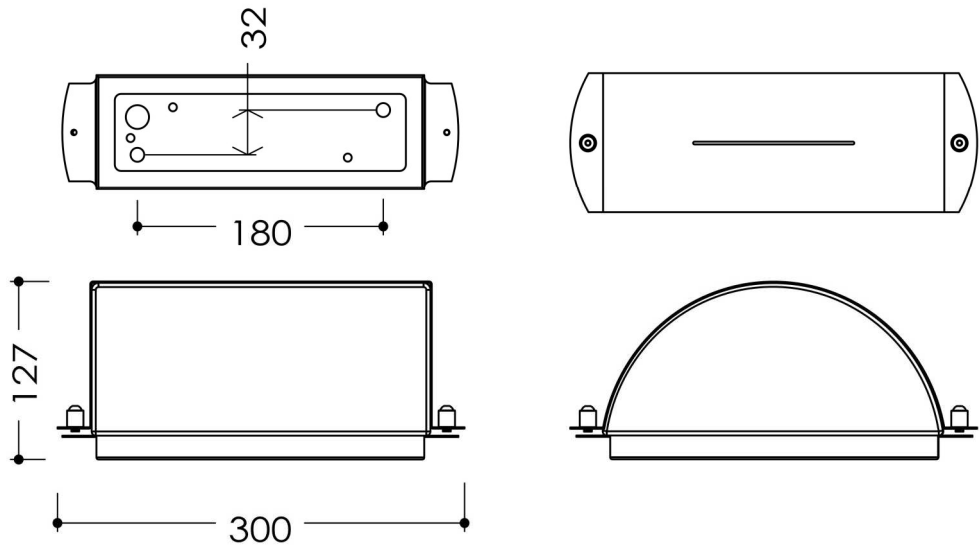

WWW.QAZQA.COM

INSTRUCTION

wall lights



Art No.: 46006/46007

LAMP: 220V--240V

Tungsten halogen lamp for mains voltage

QT 32.Max.75W / Bulb Max.75W .E27

or E27 ESL Max.12W

Please note the lamp manufactures instruction.

Product description

The armature made of copper and stainless steel

Opal glass

Reflector made of pure aluminium

2 fixing holes 4.5mm

Lamp holder E27

Safety class I

Protection class IP54

CE mark

QAZQA