

INSTALLATION INSTRUCTIONS

Please read these instructions carefully before attempting to install this product. It is advisable to keep these instructions in a safe place for future reference. Must be installed by a qualified electrician.

PARAMETER:

IP Rating	IP44
Rated Voltage	AC 220-240V, 50Hz
Rated Wattage	3xMax. 100W
Protection Class	Class I
Lampholder	E27

Electrical Installation

Always switch off the electricity supply at the mains during installation and maintenance. We recommend that the fuse is withdrawn or circuit breaker switched off at the distribution board whilst work is in progress (turning off the light switch is not sufficient).

1. A concrete filled hole with insulated piping for the mains cable need to be setup. Feed the mains cable through the insulated piping (not supplied) allowing enough surplus to connect into the terminal block.

We suggest that you use H05RN-F specification cable (not supplied) which is an outdoor grade, rubber sheathed cable. The cable must have a minimum cross sectional area of 1.0mm².

2. Fix the tripod (A) on top the concrete.
3. Insert the three anchor bolts (B) through the tripod (A) into the concrete with the threaded part above the ground.
4. The next thing can do once the concrete has dried.
5. Twist and remove the cover and install the lamp.

Replacement lamp(s) should be of the same type, voltage and wattage as specified on the label.

CAUTION: The lamp will become hot. Switch off and allow to cool before changing the lamp.

6. String the electric cord, from the lamp head (F) thru upper pole (E), lower pole (D) and base (C).
7. Attach the lamp head (F) onto the upper pole (E) and then secure the two together with the hex bolts (J3).
8. Connect the mains supply to the terminal block, using the following colour code for the wiring:
Connect the Brown (Live) wire to the corresponding terminal on the terminal block marked L.
Connect the Green/Yellow (Earth) from the mains supply to the Earth terminal marked E or .
Connect the Blue (Neutral) wire to the corresponding terminal on the terminal block marked N.
9. Lift the base (C) onto the anchor bolts (B) and secure with the nut covers (J1) and locking washers.
10. Attach base (C) to lower pole (D) using screws (J2) and locking washers.
11. Thread lower pole (D) to upper pole (E) and secure with the screw.
12. Restore mains supply and switch on.



WWW.QAZQA.COM



WWW.QAZQA.COM

Care and Use

1. This product must be earthed.
2. Please use the double-pole-off switch.
3. Replace any cracked/damaged diffuser immediately-do not use if they are damaged.

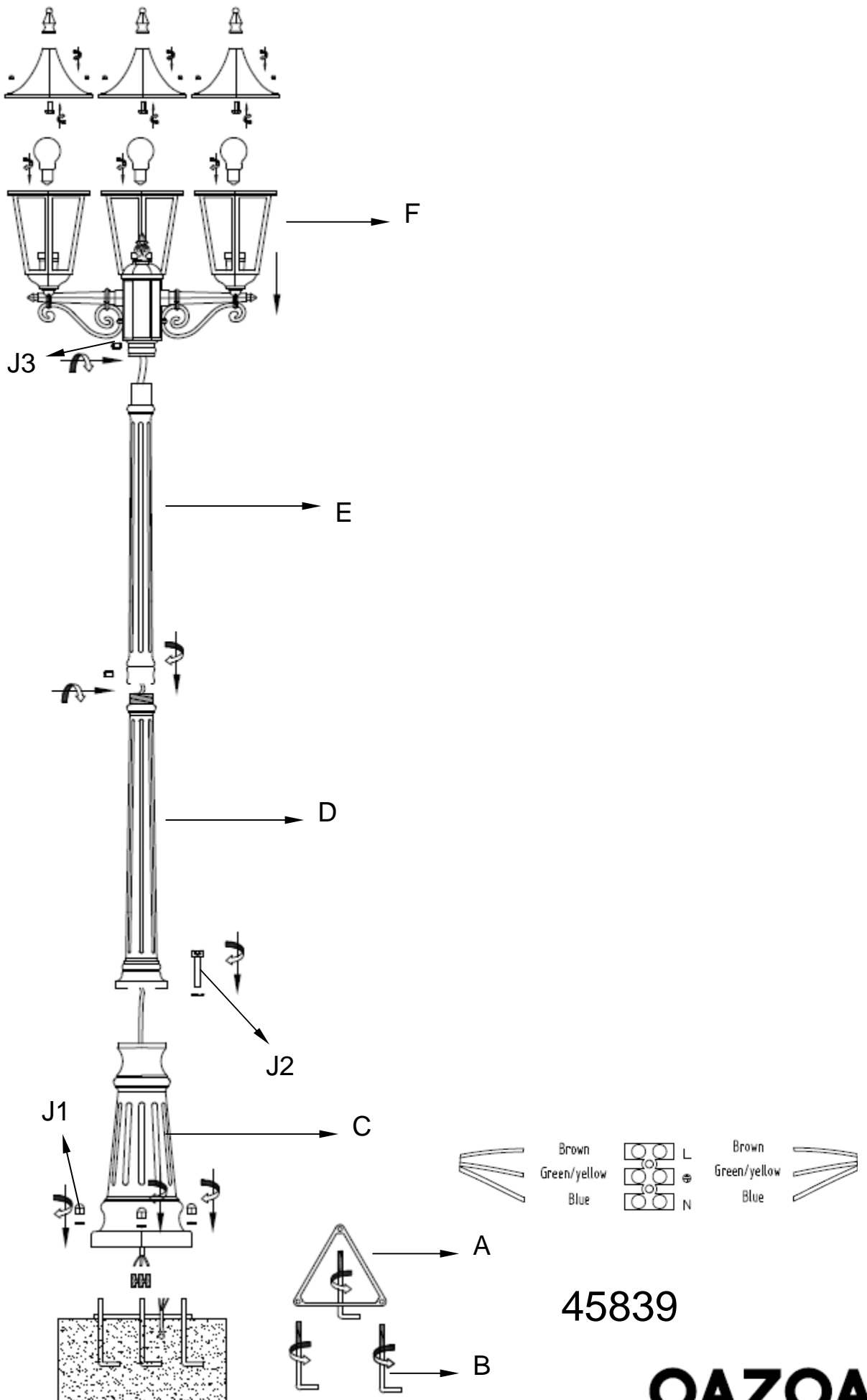

45839

QAZQA