

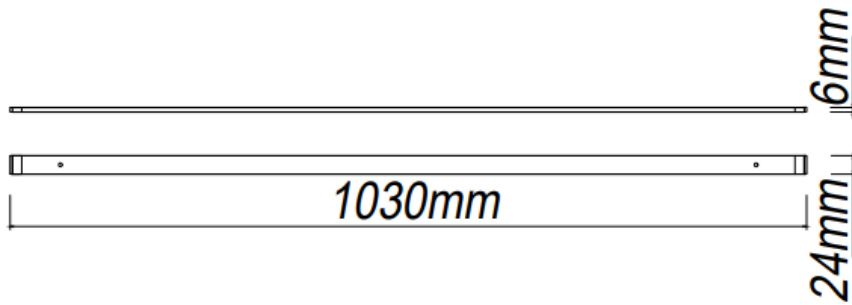



107993
48VDC / Max.10A indoor use only



(DE) Verwendete Symbole

(EN) Safety Precautions | (FR) Symboles utilisés | (NL) Gebruikte symbolen | (PL) Stosowane symbole | (NO) Brukte symboler | (DK) Brugte symboler
(SE) Använda symboler | (FI) Käytetyt symbolit | (IT) Simboli usati | (ES) Símbolos empleados | (CZ) Použité symboly | (PT) Símbolos utilizados
(GR) Χρησιμοποιούμενα σύμβολα | (SK) Bezpečnostné opatrenia | (EE) Ohutusabinõud | (LV) Drošības pasākumi
(LT) Saugos priemonės | (RO) Măsuri de precauție | (SI) Varnostni ukrepi | (HR) Mjere opreza | (HU) Használt szimbólumok | (BG) Мерки за безопасност
(AL) Simbolet e përdorura | (MK) Користени симболи | (TR) Kullanılan semboller | (UK) Використовувані символи | (BA,ME,RS) Korišteni simboli

IP 20    

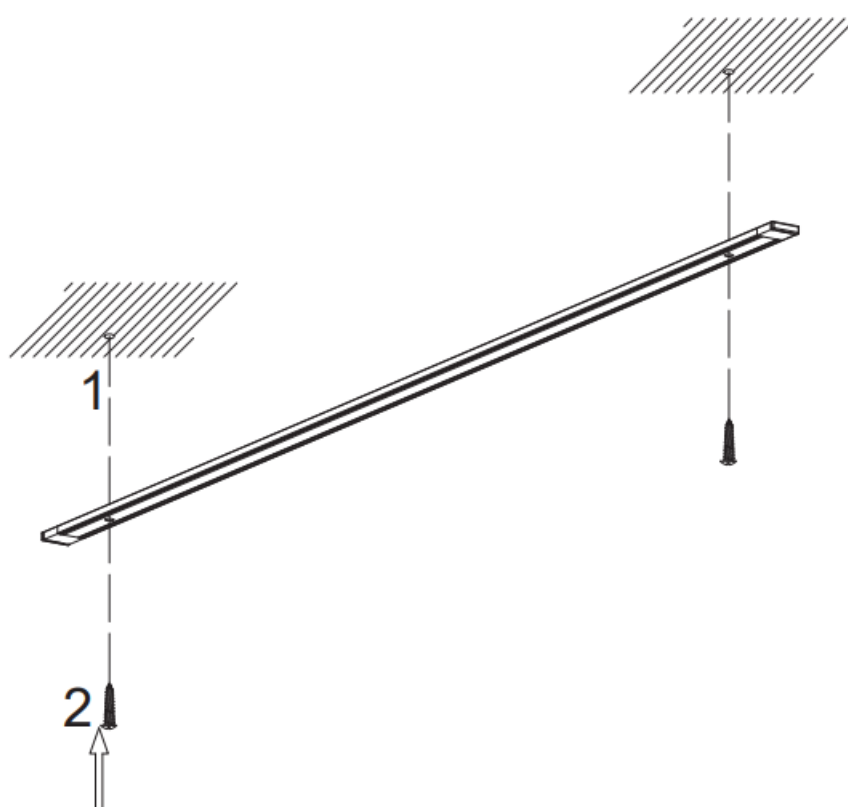

Caution: To reduce the risk of overheating and fire, do not bridge conductors.

107997

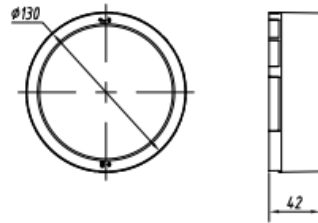

Maßeinheit/Unit of measure/ Unité de mesure: mm

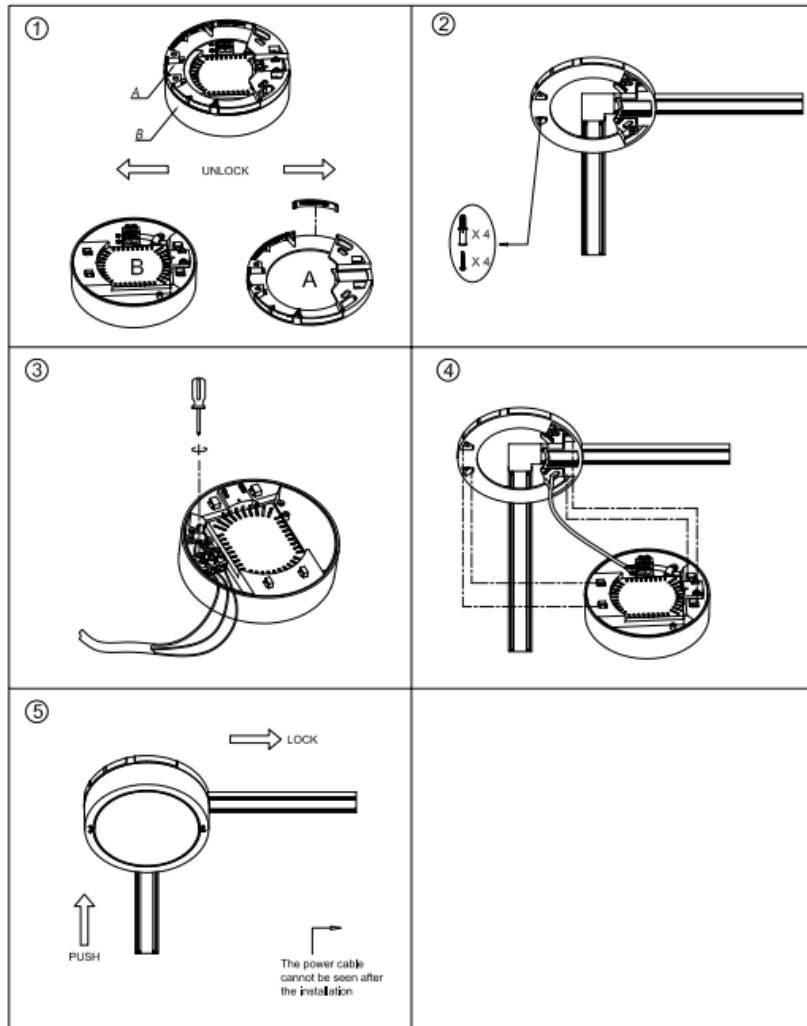

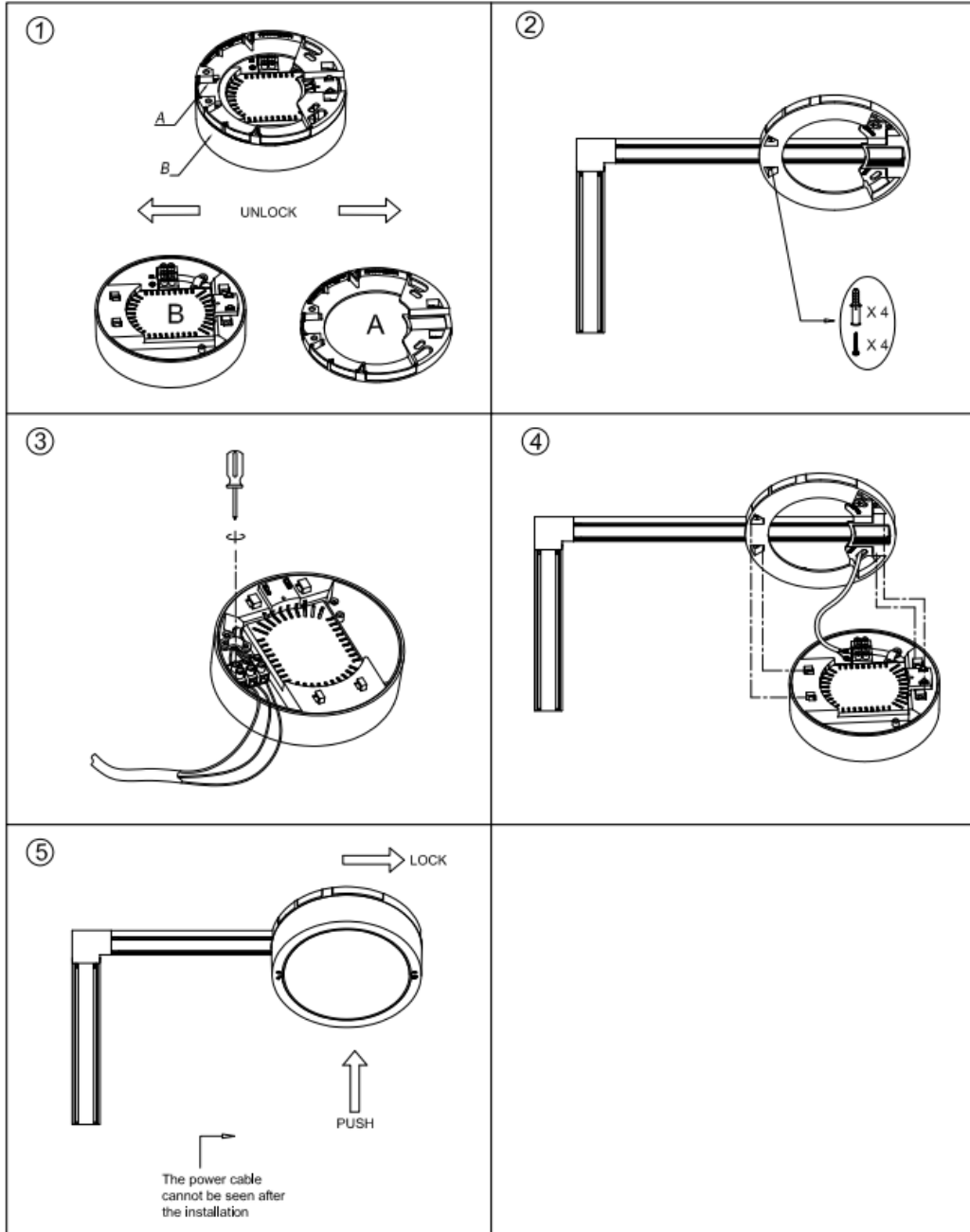

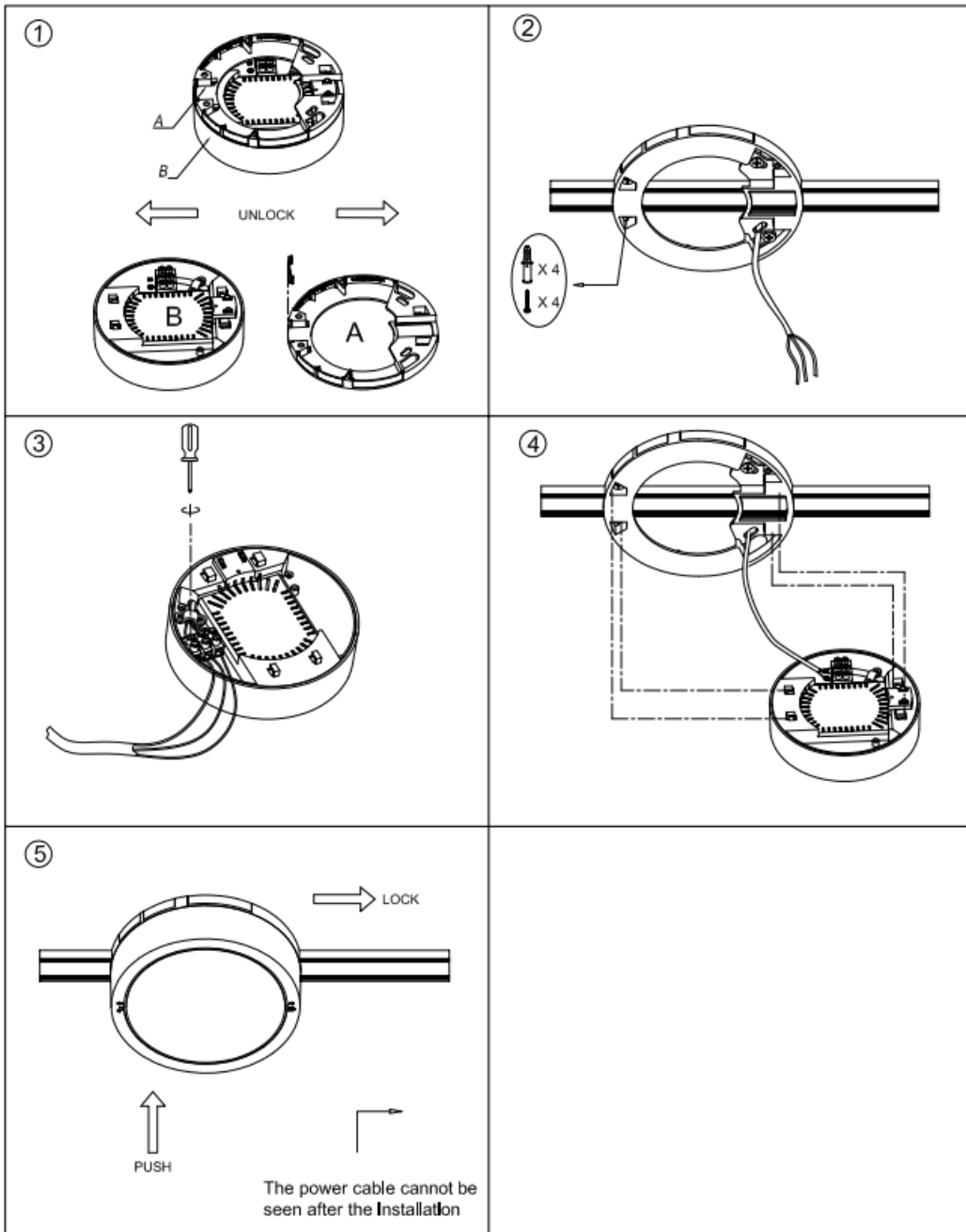

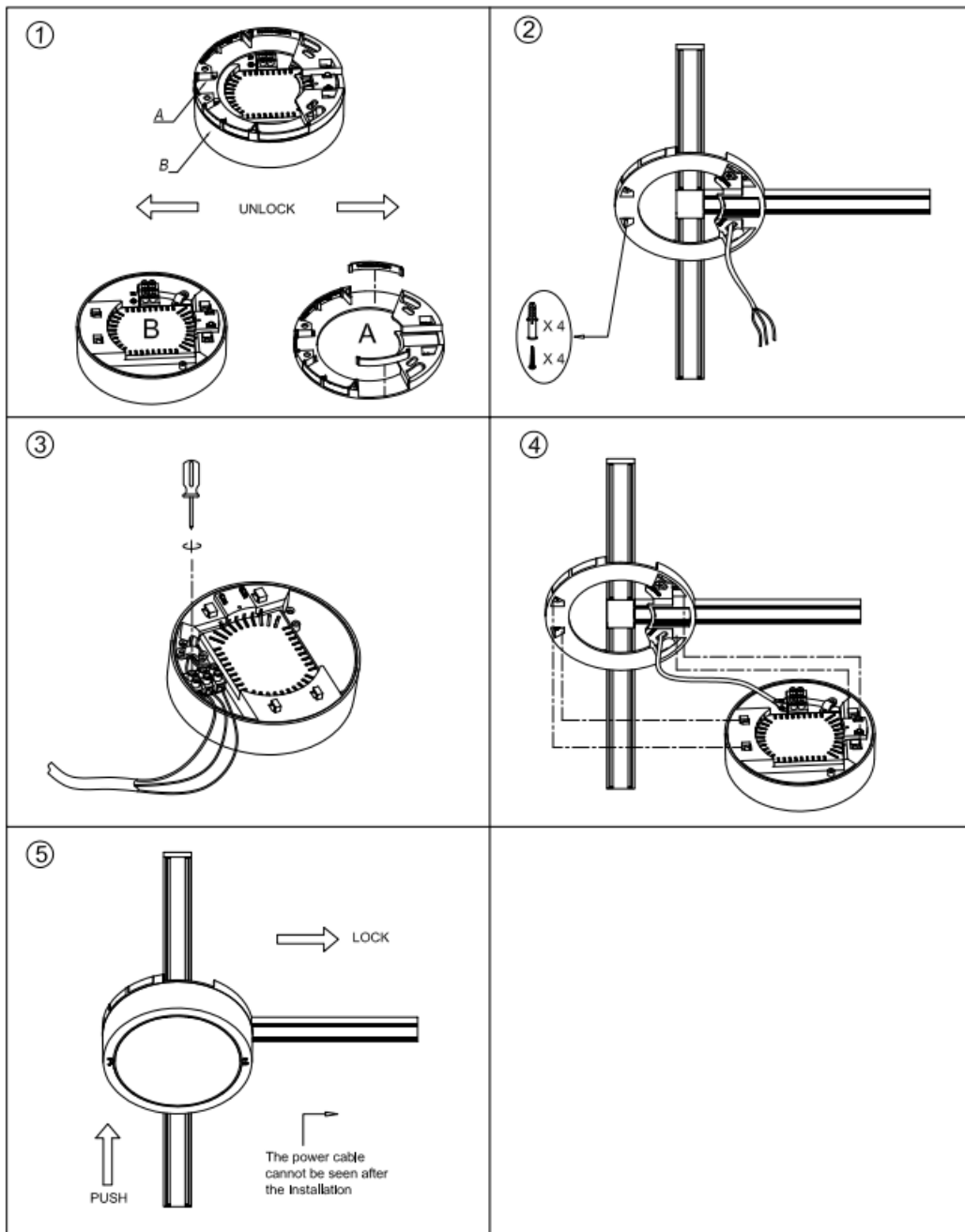

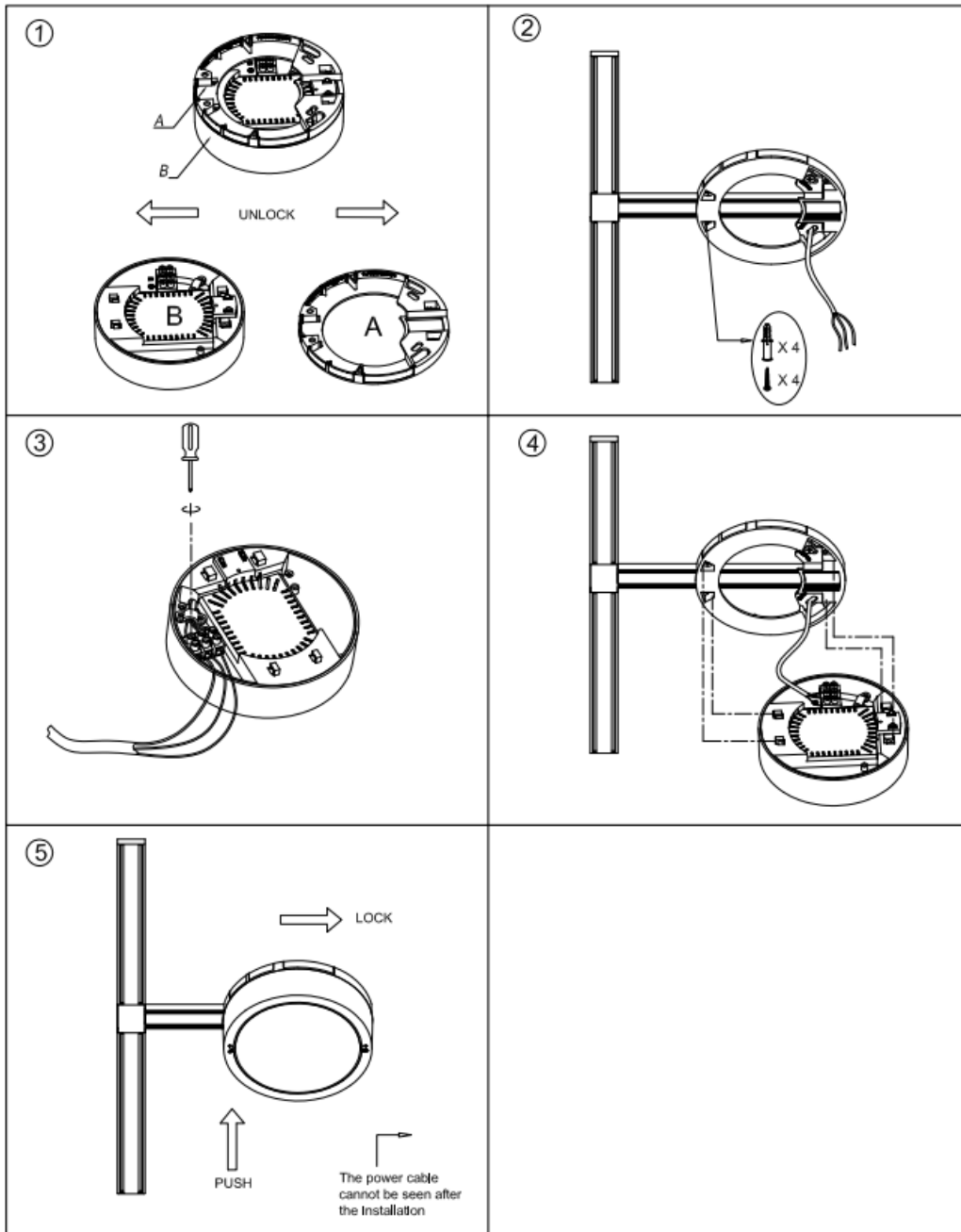

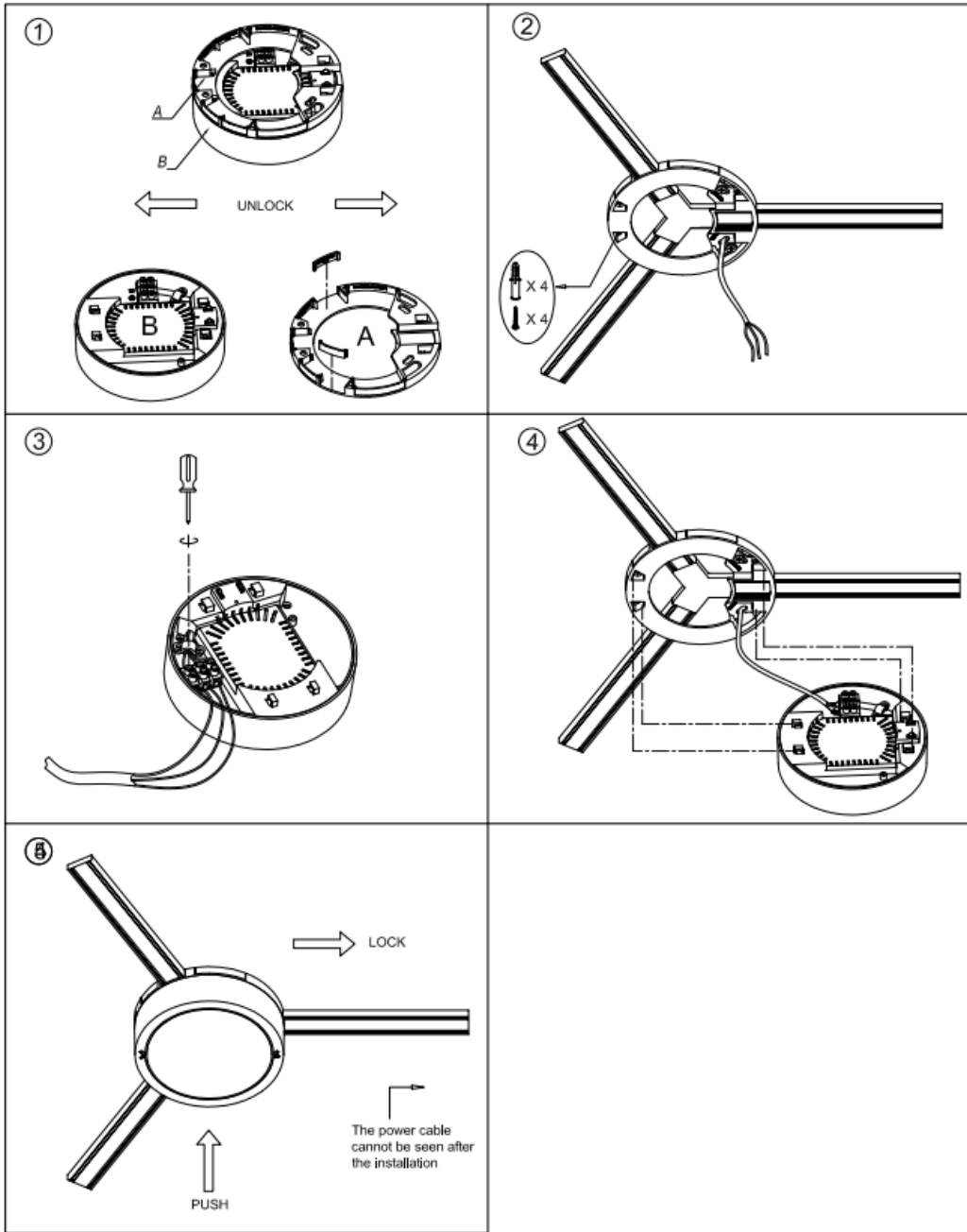

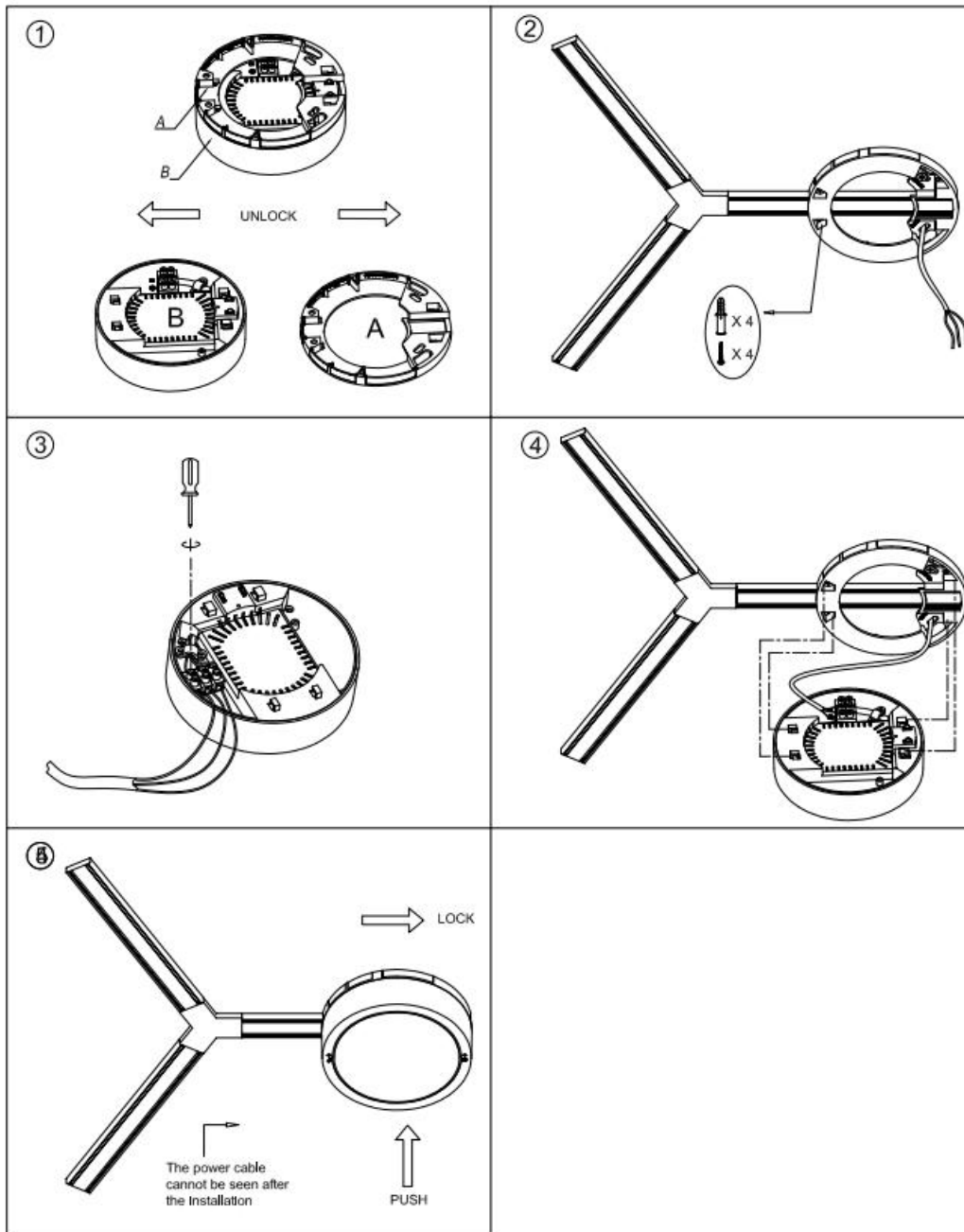

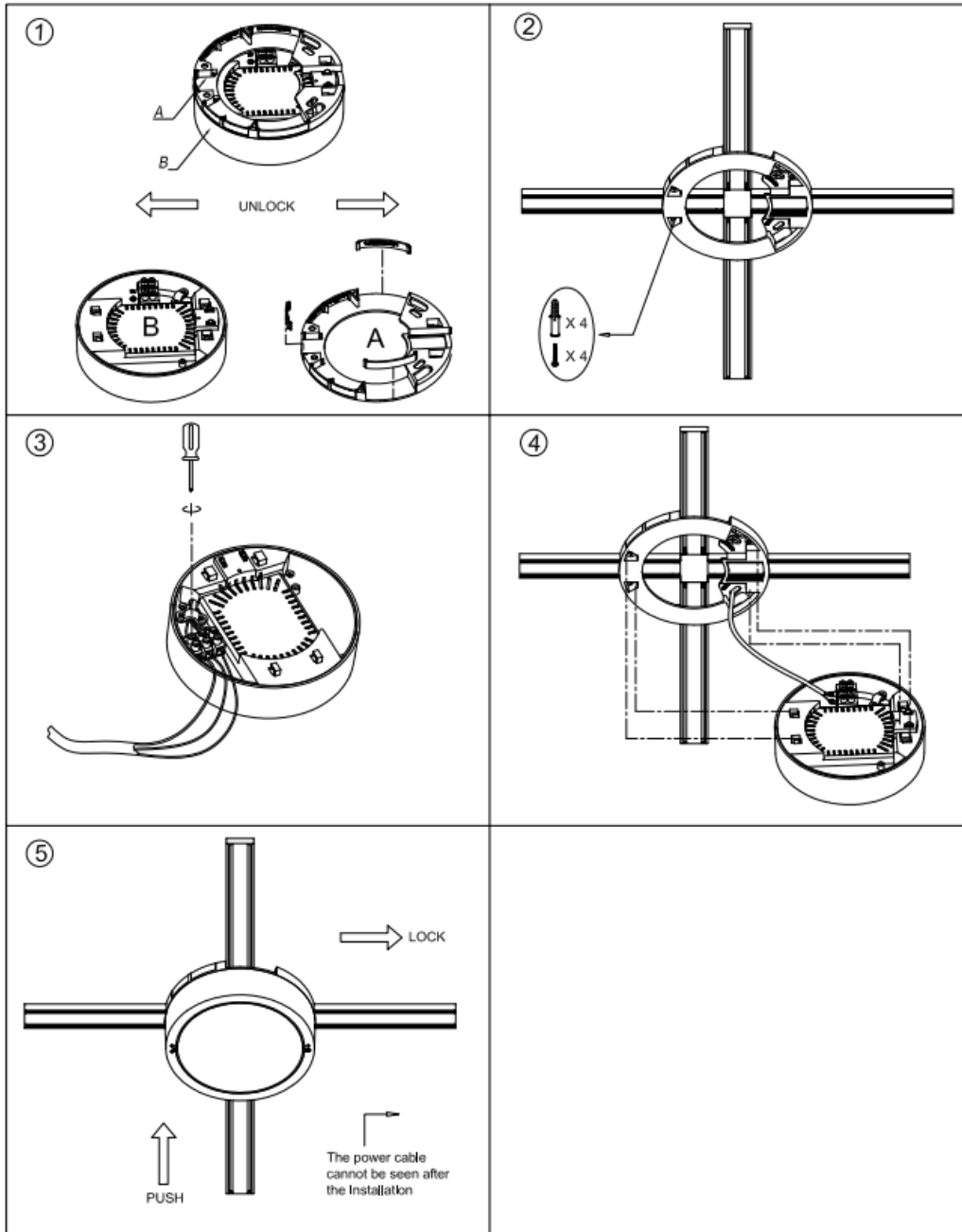

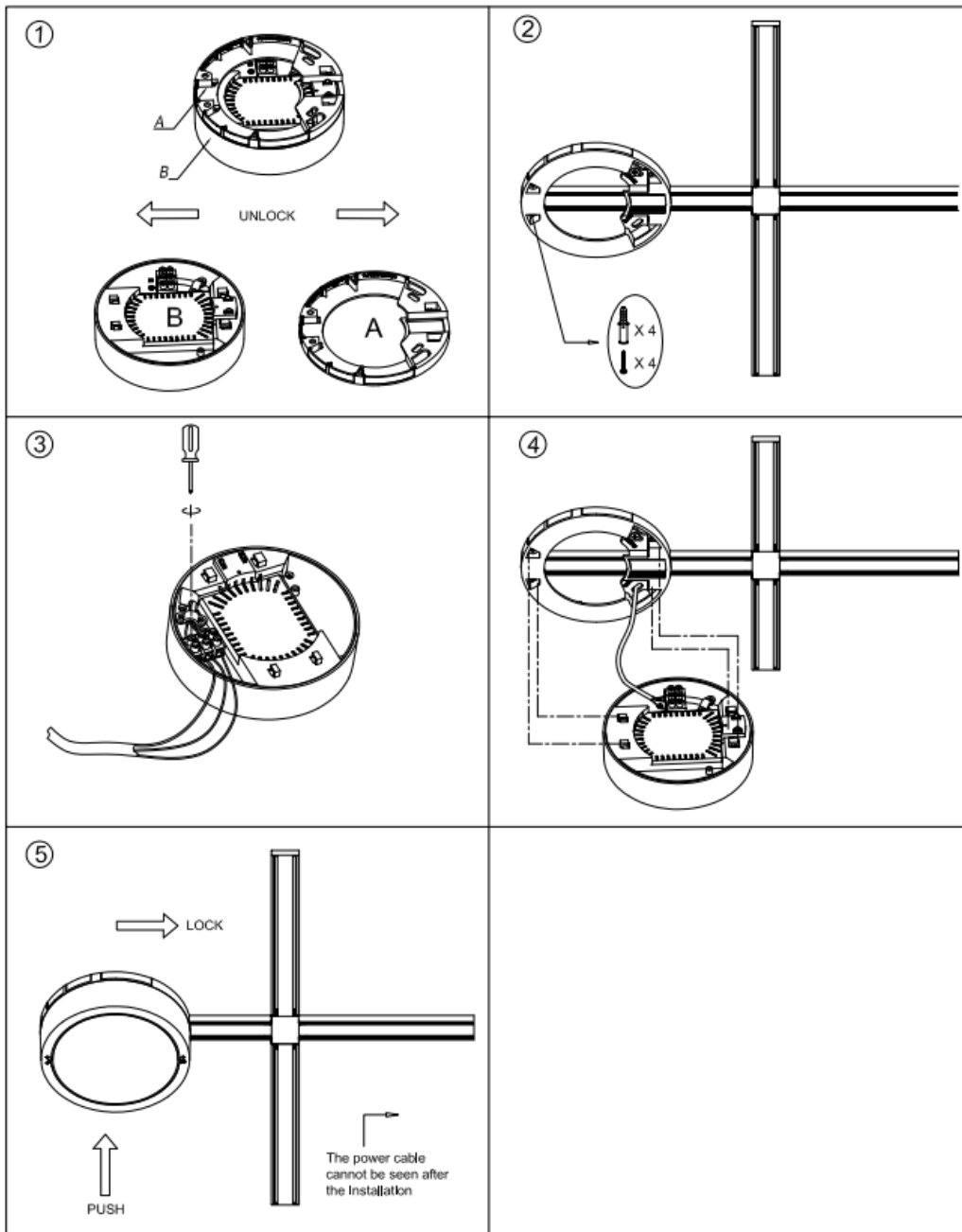

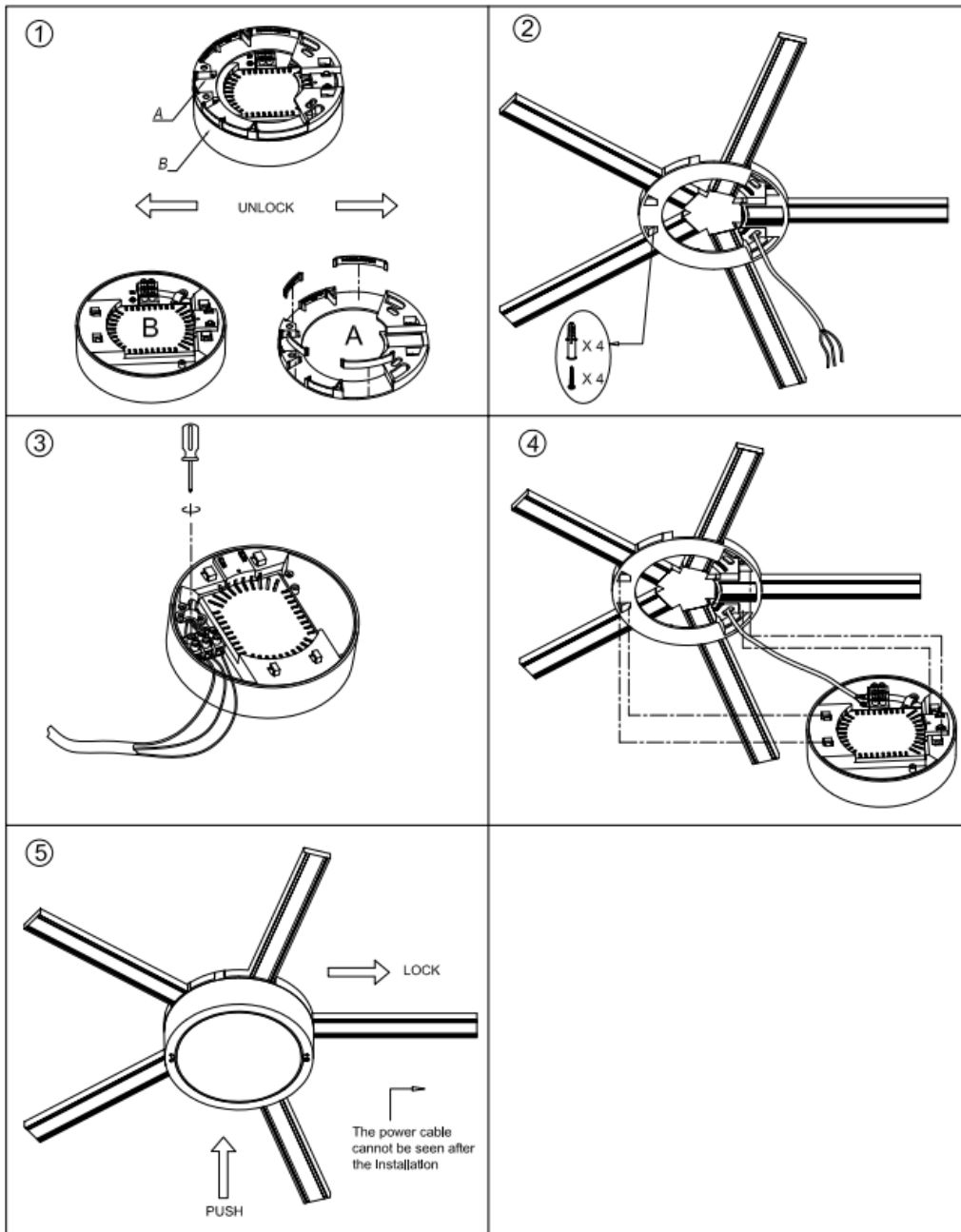

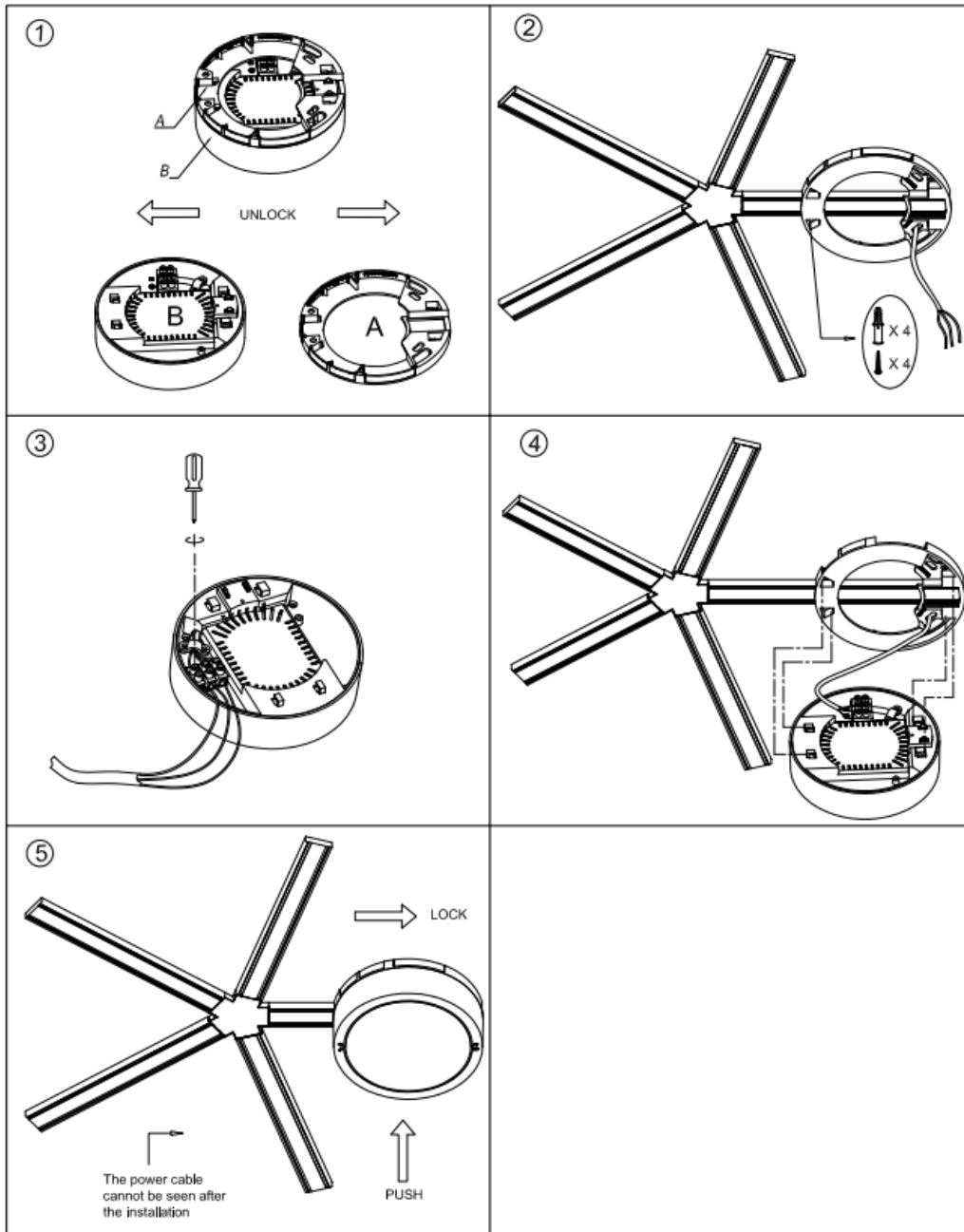

107996



(DE) Verwendete Symbole

(EN) Safety Precautions | (FR) Symboles utilisés | (NL) Gebruikte symbolen | (PL) Stosowane symbole | (NO) Brukte symboler | (DK) Brugte symboler
(SE) Använda symboler | (FI) Käytetyt symbolit | (IT) Simboli usati | (ES) Símbolos empleados | (CZ) Použité symboly | (PT) Símbolos utilizados
(GR) Χρησιμοποιούμενα σύμβολα | (SK) Bezpečnostné opatrenia | (EE) Ohutusabinõud | (LV) Drošības pasākumi
(LT) Saugos priemonės | (RO) Măsuri de precauție | (SI) Varnostni ukrepi | (HR) Mjere opreza | (HU) Használt szimbólumok | (BG) Мерки за безопасност
(AL) Simbolet e përdorura | (MK) Користени симболи | (TR) Kullanılan semboller | (UK) Використовувані символи | (BA,ME,RS) Korišteni simboli

IP 20



REMOTE CONTROL

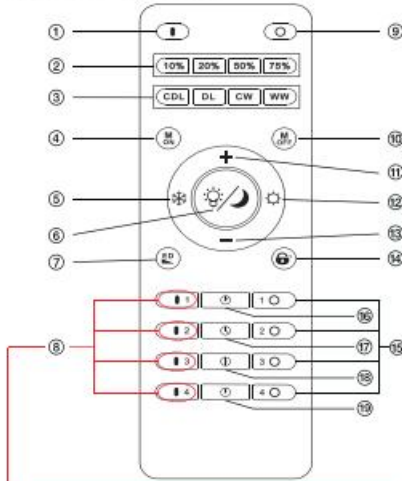

DE

Schnellstart: Halten Sie eine dieser Tasten gedrückt, während Sie die Lampe zum ersten Mal einschalten, um die Fernbedienung mit der Lampe zu verbinden.

Siehe: „Fernbedienung zuweisen“

FR

Démarrage rapide: maintenez l'une de ces touches appuyée la première fois que vous allumez la lampe pour connecter la télécommande à la lampe.

Voir: „Affecter la télécommande“

GB

Quick Start: Keep one of these buttons pressed while turning the luminaire on for the first time to connect the remote control with the luminaire.

See: „Assign the remote control“

DE

Vor der erstmaligen Verwendung der Fernbedienung, müssen Sie die Leuchte evtl. einer Fernbedienung zuweisen. Bitte befolgen Sie dazu die folgenden Schritte.

Fernbedienung zuweisen:

- Schalten Sie die Leuchte über den Wandschalter ein.
- Innerhalb 2 Sekunden die „Ein“-Taste („I“) der gewünschten Verbindungstaste drücken, bis die Leuchte aufblinkt. Das Blinken signalisiert die erfolgreiche Zuweisung der Leuchte.
- Um mehrere Leuchten einer Gruppe zuzuweisen, wiederholen Sie die zuvor genannten Schritte, bis Sie alle Leuchten zugewiesen haben.
- Wenn Sie mehrere Leuchten einer Gruppe zugewiesen haben, werden diese immer synchron geschaltet. Die Leuchten können dann nicht mehr einzeln gesteuert werden (z.B. Dimmen, Lichtfarbe ändern, Ein/Aus).

DE FERNBEDIENUNG

- | | |
|--|--|
| 1 Ein | 11 Helligkeit erhöhen |
| 2 Schnellwahlstaste Helligkeit | 12 Lichtfarbe zu warmweiß verändern |
| 3 Schnellwahlstaste weiß
CDL: kaltweiß
DL: Tageslicht
CW: neutralweiß
WW: warmweiß | 13 Helligkeit verringern |
| 4 Speicherfunktion ein | 14 Tastenfeld sperren/entsperren |
| 5 Lichtfarbe zu kaltweiß verändern | 15 Gruppe 1-4 Aus |
| 6 Nachtlicht-Modus an/aus | 16 Timer-Funktion aktivieren. Leuchte schaltet sich nach 10 Minuten aus. |
| 7 EasyDim Funktion | 17 Timer-Funktion aktivieren. Leuchte schaltet sich nach 20 Minuten aus. |
| 8 Gruppe 1-4 Ein/Verbinden | 18 Timer-Funktion aktivieren. Leuchte schaltet sich nach 30 Minuten aus. |
| 9 Aus | 19 Timer-Funktion aktivieren. Leuchte schaltet sich nach 60 Minuten aus. |
| 10 Speicherfunktion aus | |

FR CONTRÔLE À DISTANCE

- | | |
|--|--|
| 1 Allumer | 11 Augmenter la luminosité |
| 2 Touche de sélection rapide luminosité | 12 Changer la couleur de la lumière en blanc chaud |
| 3 Touche de sélection rapide blanc
CDL : blanc froid
DL : lumière du jour
CW : blanc neutre
WW : blanc chaud | 13 Diminuer la luminosité |
| 4 Activer la fonction de mémorisation | 14 Verrouillage/déverrouillage du clavier |
| 5 Changer la couleur de la lumière en blanc froid | 15 Éteindre groupe 1-4 |
| 6 Activation/désactivation du mode éclairage de nuit | 16 Activer la fonction de minuterie. La lampe s'éteint après 10 minutes. |
| 7 Fonction EasyDim | 17 Activer la fonction de minuterie. La lampe s'éteint après 20 minutes. |
| 8 Allumer/connecter groupe 1-4 | 18 Activer la fonction de minuterie. La lampe s'éteint après 30 minutes. |
| 9 Éteindre | 19 Activer la fonction de minuterie. La lampe s'éteint après 60 minutes. |
| 10 Désactiver la fonction de mémorisation | |

Zuordnung aufheben / Leuchte zurücksetzen:

- Trennen Sie die Leuchte ca. 10 Sekunden über den Wandschalter von der Stromversorgung.
- Schalten Sie die Leuchte über den Wandschalter erneut ein.
- Drücken sie den Knopf der zugeordneten Gruppe 5 mal hintereinander.
- Die Leuchte wurde erfolgreich aus der Gruppe zurückgesetzt. Die Leuchte kann jetzt erneut einer Fernbedienung oder Gruppe entsprechend der oben beschriebenen Schritte zugewiesen werden. Um weitere Leuchten aus einer Gruppe zu entfernen, wiederholen Sie bitte die zuvor genannten Schritte ebenfalls für die entsprechenden Leuchten.

Einschaltknopf/Ausschaltknopf: Durch Betätigen der Einschaltknopf/Ausschaltknopf Taste werden alle einer Fernbedienung zugewiesenen

GB REMOTE CONTROL

- | | |
|--|---|
| 1 On | 11 increase brightness |
| 2 Fast choice button brightness | 12 turn the light colour to warm white |
| 3 Fast choice button white
CDL: cold white
DL: daylight
CW: neutral white
WW: warm white | 13 decrease brightness |
| 4 Memory function on | 14 Lock/unlock the key pad |
| 5 turn the light colour to cold white | 15 Group 1-4 off |
| 6 night light mode on/off | 16 Setup timer. The lamp will turn off after 10 minutes |
| 7 EASY DIM FUNCTION | 17 Setup timer. The lamp will turn off after 20 minutes |
| 8 Group 1-4 on/connect | 18 Setup timer. The lamp will turn off after 30 minutes |
| 9 Off | 19 Setup timer. The lamp will turn off after 60 minutes |
| 10 Memory function off | |

Leuchten ein- bzw. ausgeschaltet.

Gleichzeitige Steuerung aller einer Fernbedienung zugewiesenen Leuchten:

Wenn Sie alle einer Fernbedienung zugewiesenen Leuchten gleichzeitig einstellen wollen (z.B. Lichtfarbe einstellen), müssen Sie zunächst alle Leuchten über die Taste Ausschaltknopf ausschalten und sie dann über die Taste Einschaltknopf wieder einschalten. Jetzt reagieren alle Leuchten gleichzeitig auf Ihre Eingaben.

Die Leuchten können in einem Radius von bis zu 20m mit der Fernbedienung gesteuert werden. Die Reichweite kann jedoch z.B. durch Wände oder andere Störfaktoren beeinträchtigt werden. Sollte sich die Reichweite der Fernbedienung verringern, überprüfen Sie bitte die Batterien (2x AAA, 1,5V) und wechseln diese ggf. aus.

GB

Prior to first use of the remote control, you must assign the light to the remote control. Please perform the following steps.

Assign the remote control:

1. Turn on the light at the switch on the wall.
2. You have 2 seconds to press the "On" button ("I") on the desired shortcut key. Press this button until the light flashes. Flashing indicates successful assignment of the light. To assign several lights to one group, repeat the previous steps until you have assigned all of the lights. Once you have assigned several lights to one group, these lights will always operate synchronously. The lights can no longer be controlled individually (e.g. for dimming, changing colour, on/off).

Undo assignment / reset light:

1. Disconnect the light from the power supply at the switch on the wall for approx. 10 seconds.
2. Turn the light back on at the switch on the wall.
3. Press the button of the linked group 5 times repeatedly.
4. The light has successfully reset from the previous linked group. The light can now be reassigned to a remote control or group by following the steps outlined above. To remove several lights from a group, please repeat the previous steps for each light.

Master ON/OFF:

Pressing the Master ON/OFF button will either switch on or switch off all of the lights allocated to a remote control.

Simultaneous control of all lights assigned to a remote control:

If you want to simultaneously configure all lights assigned to a remote control (e.g. setting the colour), first switch off all of the lights with the "Master OFF" button and then switch them back on with the "Master ON" button. All of the lights will now respond to your input.

The lights can be controlled within a radius of up to 20m of the remote control. However, the range may be affected by walls or other interference factors. If the range of the remote control decreases, please check the batteries (2x AAA, 1.5V) and replace them if necessary.

FR

Avant la première utilisation de la télécommande, vous devez, le cas échéant, affecter la lampe à une télécommande. Pour cela, veuillez suivre les étapes suivantes.

Affecter la télécommande:

1. Allumez la lampe avec l'interrupteur mural.
2. En l'espace de 2 secondes appuyez sur la touche « marche » (« I ») du bouton de raccourci souhaité jusqu'à ce que la lampe clignote. Le clignotement signale l'affectation correcte de la lampe. Afin d'affecter plusieurs lampes à un groupe, répétez les étapes mentionnées précédemment jusqu'à ce que toutes les lampes aient été affectées à ce groupe. Une fois que vous avez affecté plusieurs lampes à un groupe, elles seront toujours commutées de manière synchrone. Ces lampes ne peuvent plus être commandées individuellement (par ex. variation de la luminosité, modification de la couleur de la lumière, marche / arrêt).

Suppression de l'affectation / réinitialisation de la lampe:

1. Coupez la lampe de l'alimentation électrique durant environ 10 secondes au moyen de l'interrupteur mural.
2. Allumez de nouveau la lampe au moyen de l'interrupteur mural.
3. Appuyez sur le bouton du groupe lié 5 fois de suite.
4. La lampe a été réinitialisée avec succès au groupe lié antérieur.

La lampe peut ensuite de nouveau être affectée à une télécommande ou à un groupe selon les étapes décrites précédemment. Pour supprimer encore d'autres lampes dans un groupe, veuillez répéter les opérations décrites précédemment pour les lampes correspondantes.

Maître MARCHÉ / ARRÊT:

Par l'actionnement de la touche Maître / ARRÊT toutes les lampes affectées à une télécommande sont allumées et / ou éteintes.

Commande simultanée de toutes les lampes affectées à une télécommande:

Si vous souhaitez régler toutes les lampes affectées à une télécommande (par ex. régler la couleur de la lumière), vous devez tout d'abord éteindre toutes les lampes au moyen de la touche « Maître-ARRÊT » et les rallumer au moyen de « Maître-MARCHE ». Maintenant, toutes les lampes réagissent simultanément à vos commandes. Les lampes peuvent être commandées par la télécommande sur un rayon maximal de 20 m. Toutefois, la portée peut être influencée par ex. par des murs ou d'autres obstacles. Si la portée de la télécommande commence à diminuer, veuillez vérifier les piles (2x AAA, 1,5 V) et remplacez les cas échéant. Si la portée de la télécommande commence à diminuer, veuillez vérifier les piles (2x AAA, 1,5 V) et remplacez les cas échéant.

108002



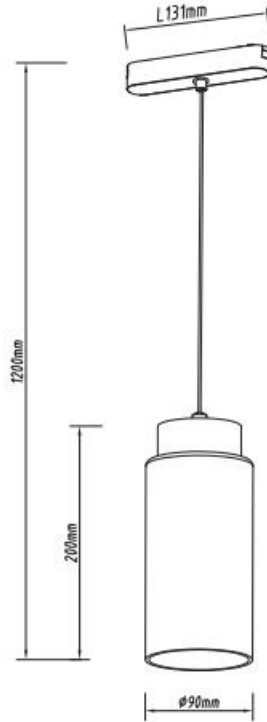

7,8W LED / 8,5W Total
incl. LED Board: QL7001363
48Vdc constant voltage 0.177A

**(DE) Bestimmungsgemäße Verwendung**

(EN) Intended use | (FR) Utilisation conforme | (NL) Beoogd gebruik | (PL) Stosowanie zgodnie z przeznaczeniem | (NO) Riktig bruk | (DK) Korrekt brug | (SE) Avsedd användning | (FI) Määräystenmukainen käyttö | (IT) Impiego appropriato | (ES) Uso prescrito | (CZ) Použití v souladu s určením | (PT) Utilização correta | (GR) Ενδεδειγμένη χρήση | (SK) Predpokladané použitie | (EE) Eeldatav kasutus | (LV) Paredzamais lietojums | (LT) Numatomas naudojimas | (RO) Utilizare intenționată | (SI) Predvidena uporaba | (HR) Namjenska upotreba | (HU) Tervezett felhasználás | (BG) предназначена употреба | (AL) Përdorimi i parashikuar | (MK) Предвидена употреба | (TR) Amaçlı kullanım | (UK) Призначене використання | (BA,ME,RS) Namjenska upotreba

(DE) Verwendung als Schienenleuchte im Innenbereich	(GB) Use as a track light indoors
(FR) Utilisation comme luminaire sur rail en intérieur	(NL) Gebruik als railverlichting binnenshuis
(PL) Użycie jako oświetlenie szynowe wewnątrz	(NO) Bruk som skinnelysning innendørs
(DK) Brug som skinnelysning indendørs	(SE) Användning som skinnelysning inomhus
(FI) Käyttö kiskovalaisimena sisätiloissa	(IT) Utilizzo come illuminazione su binario per interni
(ES) Uso como luz de riel en interiores	(CZ) Použití jako kolejové osvětlení v interiéru
(PT) Uso como iluminação de trilho em interiores	(GR) Χρήση ως φωτιστικό σώμα εσωτερικού χώρου
(SK) Použitie ako koľajové svetlo v interiéri	(BG) Използване като релсова светлина на закрито
(EE) Kasutamise rõõbasteevalgustina siseruumides	(LV) Izmantošana kā sliežu argaismojums iekšējā telpā
(LT) Naudojimas kaip bėgių šviestuvus patalpose	(RO) Utilizare ca lumină pe șină în interior
(SI) Uporaba kot tirna svetilka v notranjih prostorih	(HR) Korištenje kao tračna svjetiljka u unutrašnjosti
(HU) Használat sínvilágításként beltérben	(AL) Përdorimi si ndriçim hekurudhor brenda
(MK) Употреба како шинско светло во внатрешноста	(TR) İç mekanda raylı aydınlatma olarak kullanım
(UK) Використання як рейкове освітлення в приміщенні	(BA) Korištenje kao željezničko svjetlo u unutrašnjosti
	(ME)
	(RS)

(DE) Lieferumfang		
(EN) Package contents (FR) Contenu de la livraison (NL) Bij de levering inbegrepen (PL) Zakres dostawy (NO) Levering (DK) Leveringsomfang (SE) Leveransomfattning (FI) Toimitussisältö (IT) Fornitura (ES) Volumen de suministro (CZ) Rozsah dodávky (PT) Material fornecido (GR) Παράδοτος εξοπλισμός (SK) Obsah balenia (EE) Pakendi sisu (LV) Pakas saturs (LT) Pakuotės turinys (RO) Conținutul pachetului (SI) Vsebina paketa (HR) Sadržaj paketa (HU) A csomag tartalma (BG) обхват на доставката (AL) Përmbajtja e dorëzimit (MK) Содржина на испорака (TR) Teslimat içeriği (UK) Зміст доставки (BA,ME,RS) Sadržaj isporuke		
(DE) 1 Schienenleuchte Montagematerial Montageanleitung	(GB) 1 track light Installation hardware Mounting instructions	(FR) 1 luminaire sur rail Matériel de montage Instructions de montage
(NL) 1 railverlichtin Monteringsmateriale Montagehandleiding	(PL) 1 oświetlenie szynowe Elementy montażowe Instrukcja montażu	(NO) 1 skinnebelysning Monteringsmateriale Brukerveiledning
(DK) 1 skinnebelysning Monteringsmateriale Brugervejledning	(SE) 1 skenbelysning Monteringsmaterial Monteringsanvisning	(FI) 1 kiskovalaisin Asennusmateriaali Asennusohjeet
(IT) 1 illuminazione su binario Materiale di montaggio Istruzioni di montaggio	(ES) 1 luz de riel Material de montaje Instrucciones de montaje	(CZ) 1 kolejové osvětlení Materiál pro montáž Návod k montáži
(PT) 1 iluminação de trilho Material de montagem Instruções de montagem	(GR) 1 φωτιστικό ράγας Υλικά συναρμολόγησης Οδηγίες συναρμολόγησης	(SK) 1 kolajové svetlo Inštaláčny hardvér Inštaláčna príručka
(BG) 1 релсова светлина материали за монтаж инструкции за монтаж	(EE) 1 rööbasteevalgusti Paigaldustarvikud Paigaldusjuhend	(LV) 1 sliežu apgaismojums Instalācijas aparātūra Uzstādīšanas instrukcija
(LT) 1 bėgių šviestuvas Montavimo aparatinė įranga Montavimo instrukcija	(RO) 1 lumină pe șină Hardware de instalare Instrucțiuni de montare	(SI) 1 tirma svetilka Namestitvena strojna oprema Navodila za montažo
(HR) 1 tračna svjetiljka Instalacijski hardver Upute za montažu	(HU) 1 sínvilágítás Telepítési hardver Szerelési útmutató	(AL) 1 ndriçim hekurudhor Materiali i montimit Udhëzuesi i montimit
(MK) 1 шинско светло Монтажен материјал Упатство за монтажа	(TR) 1 raylı aydınlatma Montaj malzemesi Montaj kılavuzu	(UK) 1 рейкове освітлення Монтажний матеріал Інструкція з монтажу
(BA) 1 željezničko svjetlo		
(ME) Montažni materijal		
(RS) Uputstvo za montažu		

(DE) Verwendete Symbole	
(EN) Safety Precautions (FR) Symboles utilisés (NL) Gebruikte symbolen (PL) Stosowane symbole (NO) Brukte symboler (DK) Brugte symboler (SE) Använda symboler (FI) Käytetyt symbolit (IT) Simboli usati (ES) Símbolos empleados (CZ) Použité symboly (PT) Símbolos utilizados (GR) Χρησιμοποιούμενα σύμβολα (SK) Bezpečnostné opatrenia (EE) Ohutusabinõud (LV) Drošības pasākumi (LT) Saugos priemonės (RO) Măsurii de precauție (SI) Varnostni ukrepi (HR) Mjere opreza (HU) Használt szimbólumok (BG) Мерки за безопасност (AL) Simbolet e përdorura (MK) Користени симболи (TR) Kullanılan semboller (UK) Використовувані символи (BA,ME,RS) Korišteni simboli	
IP 20	   

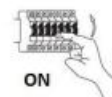
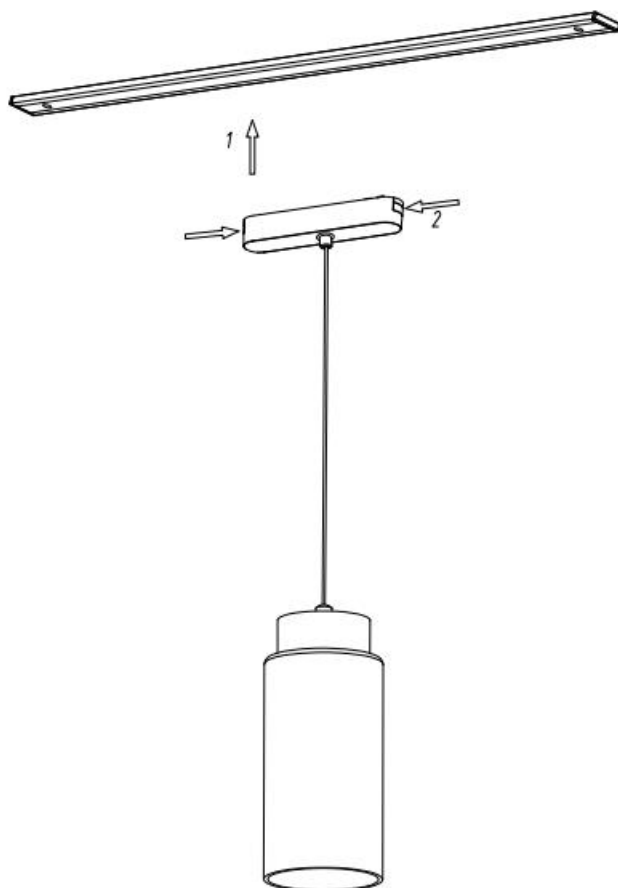

<p>(DE) Dieses Produkt enthält eine Lichtquelle der Energieeffizienzklasse F (EN) This product contains a light source of energy efficiency class F (FR) Ce produit comprend une source de lumière de classe d'efficacité énergétique F (NL) Dit product bevat een lichtbron van energie-efficiëntieklasse F (PL) Produkt ten zawiera źródło światła o klasie efektywności energetycznej F (NO) Dette produktet inneholder en lyskilde i energieeffektivitetsklasse F (DK) Dette produkt indeholder en lyskilde af energieeffektklasse F (SE) Denna produkt innehåller en ljuskälla i energieeffektivitetsklass F (FI) Tämä tuote sisältää energiatehokkuusluokan F valonlähteen (IT) Questo prodotto contiene una sorgente luminosa della classe di efficienza energetica F (ES) Este producto contiene una fuente de luz de la clase de eficiencia energética F (CZ) Tento výrobek obsahuje světelný zdroj třídy energetické účinnosti F (PT) Este produto contém uma fonte de luz da classe de eficiência energética F (GR) Αυτό το προϊόν περιέχει μια φωτεινή πηγή ενεργειακής απόδοσης κλάσης F (SK) Tento výrobok obsahuje zdroj svetla triedy energetickej efektivity F (EE) See toode sisaldab energiatõhusklassi F valgusallikat (LV) Šis produkts satur enerģijas efektivitātes klases F gaismas avotu (LT) Šis gaminys turi energijos efektyvumo klasės F šviesos šaltinį (RO) Acest produs conține o sursă de lumină de clasă de eficiență energetică F (SI) Ta izdelek vsebuje svetlobni vir energijskega razreda F (HR) Ovaj proizvod sadrži izvor svjetlosti energetske učinkovitosti klase F (HU) Ez a termék egy F energiatékonysági osztályú fényforrást tartalmaz (BG) Този продукт съдържа източник на светлина с клас на енергийна ефективност: F (AL) Ky produkt përmban një burim drite të klasës së efikasitetit të energjisë F (MK) Овој производ содржи извор на светлина од класа на енергетска ефикасност F (TR) Bu ürün, enerji verimliliği sınıfı F olan bir ışık kaynağı içerir (UK) Цей продукт містить джерело світла класу енергоефективності F (BA)(ME)(RS) Ovaj proizvod sadrži izvor svjetlosti energetske klase F</p>	<p>QR</p> 	<p>EAN</p> <p>8718881163784</p>
---	--	---------------------------------

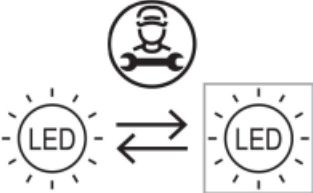
	<p>(DE) Durch einen Fachmann austauschbare Lichtquelle (nur LED). (EN) Replaceable (LED only) light source by a professional. (FR) Source de lumière remplaçable (LED uniquement) par un professionnel. (NL) Lichtbron (alleen led) te vervangen door een professional. (PL) Wymienne (tylko LED) źródło światła wykonane przez profesjonalistę. (NO) Utskiftbar (kun LED) lyskilde av en profesjonell. (DK) Udskiftelig lyskilde (kun LED), udskiftes af en elektriker. (SE) Ljuskälla (endast LED) utbytbar genom fackman. (FI) Ammattilainen voi vaihtaa vaihdettavan (vain LED) valonlähteen. (IT) Sorgente luminosa (solo LED) sostituibile da un professionista. (ES) Fuente de luz (solo LED) sustituible por un profesional. (CZ) Výměnitelný (pouze LED) světelný zdroj odborníkem. (PT) Luz LED (apenas LED) substituível por um profissional. (GR) Η πηγή φωτός (μόνο LED) να αντικαθίσταται από επαγγελματία. (SK) Zdroj svetla (iba LED) vymeniteľný prostredníctvom odborníka. (EE) Spetsialisti poolt vahetatav valgusallikas (ainult LED). (LV) Speciālistā maināms gaismas avots (tikai LED). (LT) Specialisto keičiamas šviesos šaltinis (tik LED). (RO) Sursă de lumină schimbabilă de către un specialist (doar LED). (SI) Svetlobni vir, ki ga lahko zamenja strokovnjak (samo LED). (HR) Izvor svjetlosti koji može zamijeniti stručnjak (samo LED). (HU) Szakember által cserélhető (csak LED) fényforrás. (BG) Светлинен източник, който може да се смени от специалист (само LED). (AL) Burim drite i zëvendësueshëm (LED vetëm) nga një profesionist. (MK) Изворот на светлина (само LED) се заменува од професионалец. (TR) Değiştirilebilir (yalnızca LED) ışık kaynağı bir profesyonel tarafından değiştirilir. (UK) Замінний (тільки LED) джерело світла замінюється фахівцем. (BA)(ME)(RS) Zamjenjiv (samo LED) izvor svjetlosti zamjenjuje profesionalac.</p>
---	--

	<p>(DE) Durch einen Fachmann austauschbares Betriebsgerät. (EN) Replaceable control gear by a professional. (FR) Contrôleur remplaçable par un professionnel. (NL) Voorschakelapparatuur te vervangen door een professional. (PL) Wymienny układ sterujący przez profesjonalistę. (NO) Utskiftbar kontrollutstyr av en profesjonell. (DK) Udskiftelig igangsætter, udskiftes af en elektriker. (SE) Styrdon utbytbar genom fackman. (FI) Ammattilainen voi vaihtaa vaihdettavat ohjauslaitteet. (IT) Dispositivo di controllo sostituibile da un professionista. (ES) Dispositivo de control sustituible por un profesional. (CZ) Vyměnitelný předřadník odborníkem. (PT) Dispositivo de controlo substituível por um profissional. (GR) Ο εξοπλισμός ελέγχου να αντικαθίσταται από επαγγελματία. (SK) Predradník vymeniteľný prostredníctvom odborníka. (EE) Spetsialisti poolt vahetatav juhtseade. (LV) Speciālists maināma vadības iekārta. (LT) Specialisto keičiamas valdymo įrenginys. (RO) Aparat de comandă schimbabil de către un specialist. (SI) Nadomestna krmilna naprava, ki jo lahko zamenja strokovnjak. (HR) Zamjenjivi upravljački sklop koji može zamijeniti stručnjak. (HU) Szakember által cserélhető vezérlőszervezet. (BG) Уред, който може да се смени от специалист. (AL) Pajisje kontrolli e zëvendësueshme nga një profesionist. (MK) Заменлива контролна опрема од страна на професионалец. (TR) Profesyonel tarafından değiştirilebilir kontrol donanımı. (UK) Замінний контрольний пристрій фахівцем. (BA)(ME)(RS) Zamjenjiva kontrolna oprema od strane profesionalca.</p>
---	--

